

Adjustment Instructions and Parts List for the HFP Valve

Model No. S90-252 HFP

Model No. E90-252HFP

HFP Valve Adjustment Instructions

NOTE: Refer to the illustration and parts list on page 2.

1. Turn off the water supply to the HFP valve.
2. Insert a 3/16" hex wrench into the broached/hex end of the lifting stem (Item 8).
3. Holding the lifting stem (Item 8) in place, back off the stop nut (Item 21).
4. Back off the bar nut (Item 19) by turning the handle assembly (Item 1).
5. Tighten the bonnet nut (Item 3).
6. Run the bar nut (Item 19) down by turning the handle assembly (Item 1) until the bar nut sits on the stainless steel washer (Item 2). Then back off the bar nut approximately 1/4" turn until the handle assembly returns to its original position.
7. Tighten the stop nut (Item 21) down on the bar nut (Item 19).
8. Open the water supply line to the unit. Test for leaks and adequate water flow.

Troubleshooting Instructions for Valve Leakage

NOTE: Through normal daily usage the valve may begin to leak. If leakage occurs, follow the procedure outlined below (refer to the illustration and parts list on page 2):

1. Turn off the water supply to the HFP valve.
2. Loosen the bonnet nut (Item 3) only. DO NOT loosen the stop nut (Item 21) or the bar nut (Item 19).
3. Remove the bonnet nut (Item 3) and handle assembly (Item 1) to expose the lifting stem (Item 8).
4. Check the condition of the faucet washer (Item 14) at the end of the lifting stem (Item 8). If the faucet washer is scored or worn, replace it with a new one.
5. If the faucet washer (Item 14) is undamaged, or after replacing the faucet washer, re-insert the lifting stem (Item 8) into the casing pipe (Item 7). Care must be taken to make sure the guide (Item 10) does not get hung up as the lifting stem is lowered.
6. Hand tighten the bonnet nut (Item 3).
7. Open the water supply line to the unit. Test for leaks and adequate water flow.

[Bradley S19-110HFP18 Free Standing Safety Drench Shower](#)

[Bradley S19-110HFP3 Free Standing Safety Drench Shower](#)

[Bradley S19-110HFP4 Free Standing Safety Drench Shower](#)

[Bradley S19-110HFP5 Free Standing Safety Drench Shower](#)

[Bradley S19-110HFP6 Free Standing Safety Drench Shower](#)

HFP Valve Parts Breakdown

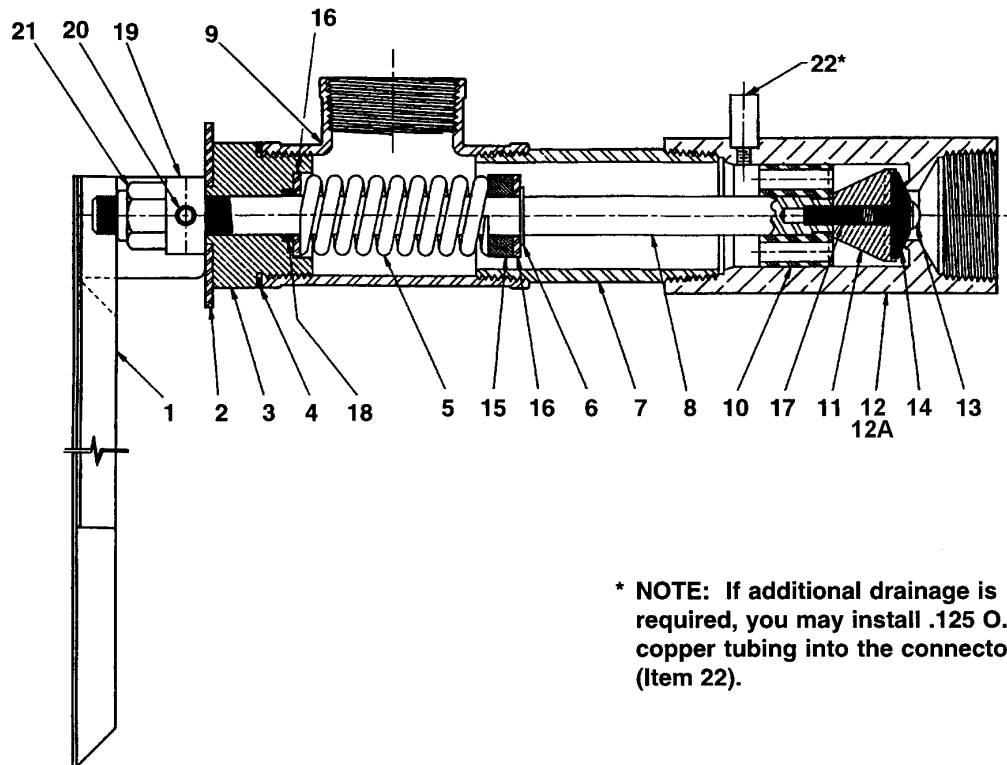

*** NOTE:** If additional drainage is required, you may install .125 O.D. copper tubing into the connector (Item 22).

Item	Part No.	Qty	Description	Item	Part No.	Qty	Description
1	S08-040	1	HANDLE ASSY.	8	120-022L	1	LIFTING STEM (3' EUROPE)
2	142-002BB	1	STN. STL. WASHER	9	169-727A	1	TEE
3	110-108	1	BONNET NUT	10	145-072	1	GUIDE
4	124-001BS	1	GASKET	11	132-011	1	RETAINER
5	135-001AP	1	SPRING	12	118-246	1	VALVE BODY ASSY.
6	132-012	1	RETAINING RING	12A	118-246B	1	VALVE BODY ASSY. EUROPE
7	113-772	1	CASING PIPE (18" BURY DEPTH)	13	160-138	1	MACHINE SCREW
7	113-773	1	CASING PIPE (3' BURY DEPTH)	14	169-920	1	FAUCET WASHER
7	113-774	1	CASING PIPE (4' BURY DEPTH)	15	182-061	1	SPACER
7	113-775	1	CASING PIPE (5' BURY DEPTH)	16	142-002CC	3	WASHER
7	113-776	1	CASING PIPE (6' BURY DEPTH)	17	160-251	1	SCREW STUD
7	113-987	1	CASING PIPE (3' EUROPE)	18	125-001CD	1	O-RING
8	120-022K	1	LIFTING STEM (18" BURY DEPTH)	19	110-109	1	BAR NUT
8	120-022D	1	LIFTING STEM (3' BURY DEPTH)	20	165-038	2	ROLL PIN
8	120-022E	1	LIFTING STEM (4' BURY DEPTH)	21	161-061	1	STOP NUT
8	120-022F	1	LIFTING STEM (5' BURY DEPTH)	22	169-890	1	CONNECTOR
8	120-022G	1	LIFTING STEM (6' BURY DEPTH)				