



Vacuum Pump Models QV2 & QV5

Instruction 2002-0010

Operation & Maintenance

Rev. 3 – April 2009



CSA 22.2 No. 1010-1

Product Leadership • Training • Service • Reliability

WARRANTY

Bacharach, Inc. warrants to Buyer that at the time of delivery this Product will be free from defects in material and manufacture and will conform substantially to Bacharach Inc.'s applicable specifications. Bacharach's liability and Buyer's remedy under this warranty are limited to the repair or replacement, at Bacharach's option, of this Product or parts thereof returned to Seller at the factory of manufacture and shown to Bacharach Inc.'s reasonable satisfaction to have been defective; provided that written notice of the defect shall have been given by Buyer to Bacharach Inc. within one (1) year after the date of delivery of this Product by Bacharach, Inc.

Bacharach, Inc. warrants to Buyer that it will convey good title to this Product. Bacharach's liability and Buyer's remedy under this warranty of title are limited to the removal of any title defects or, at the election of Bacharach, to the replacement of this Product or parts thereof that are defective in title.

THE FOREGOING WARRANTIES ARE EXCLUSIVE AND ARE GIVEN AND ACCEPTED IN LIEU OF (I) ANY AND ALL OTHER WARRANTIES, EXPRESS OR IMPLIED, INCLUDING WITHOUT LIMITATION THE IMPLIED WARRANTIES OF MERCHANTABILITY AND FITNESS FOR A PARTICULAR PURPOSE; AND (II) ANY OBLIGATION, LIABILITY, RIGHT, CLAIM OR REMEDY IN CONTRACT OR TORT, WHETHER OR NOT ARISING FROM BACHARACH'S NEGLIGENCE, ACTUAL OR IMPLIED. The remedies of the Buyer shall be limited to those provided herein to the exclusion of any and all other remedies including, without limitation incidental or consequential damages. No agreement varying or extending the foregoing warranties, remedies or this limitation will be binding upon Bacharach, Inc. unless in writing, signed by a duly authorized officer of Bacharach.

**Register your warranty by visiting
www.bacharach-inc.com**

Notice:

Product improvements and enhancements are continuous, therefore the specifications and information contained in this document may change without notice.

Bacharach, Inc. shall not be liable for errors contained herein or for incidental or consequential damages in connection with the furnishing, performance, or use of this material.

No part of this document may be photocopied, reproduced, or translated to another language without the prior written consent of Bacharach, Inc.

Copyright © 2005-2009, Bacharach, Inc., all rights reserved.
 BACHARACH is a registered trademark of Bacharach, Inc. All other trademarks, trade names, service marks and logos referenced herein belong to their respective companies.

Contents

Introduction	2
Features	2
Technical Characteristics	3
Pump Components	3
Operation.	4
Warnings & Cautions.	4
Warnings:	4
Cautions:	5
Troubleshooting	6
Maintenance and Service	7
Exploded Drawing	8

Introduction

Thank you for selecting Bacharach products for your refrigeration equipment needs. To ensure your safety, and for the safe operation of this equipment, please read, understand, and follow the information contained in this instruction manual.

The Model QV2 and QV5 are two-stage, rotary vane vacuum pumps designed to evacuate moisture and air from refrigeration systems (e.g., R-12, R-22, R-134a).

Features

- **Anti-oil-return** – A check valve prevents pump-oil from entering the evacuated system after the pump stops.
- **Environment protection** – A built-in filter eliminates oil mist, and an oil-gas separator removes oil contamination from the exhaust.
- **Aluminum alloy motor casing** – The motor casing is an aluminum alloy that has high rate of heat dissipation, which provides for continuous pump operation.
- **Two stage design** – The second stage of the two-stage design starts pumping at a lower pressure to pull a deeper ultimate vacuum.
- **High starting torque** – Designed for low temperature and low voltage operation, the pump will start in temperatures ≥ 40 °F (≥ 5 °C), at its rated input voltage of 110 VAC $\pm 10\%$.
- **Oil circulation design** – Offset rotary vanes work in conjunction with the vacuum pump oil to create high compression within the pumping chamber.

Technical Characteristics

Model	QV2	QV5
Part No.	2002-0001	2002-0005
Voltage	110V 60 Hz	110V 60 Hz
Free Air Displacement	1.7 CFM	5.3 CFM
Ultimate Vacuum	25 microns (0.03 mbar)	25 microns (0.03 mbar)
Motor	1/4 HP	1/2 HP
Intake Fitting	1/4", 3/8", 1/2" Flare	1/4", 3/8", 1/2" Flare
Motor Speed	1,720 rpm	3,450 rpm
Oil Capacity	11.8 fl. oz (350 ml)	15.2 fl. oz (450 ml)
Dimensions	14.1 x 6.8 x 11.4 in (358 x 172 x 290 mm)	14.1 x 7.1 x 11.8 in (358 x 180 x 300 mm)
Weight	21.6 lb (9.8 Kg)	26.5 lb (12 Kg)

Pump Components

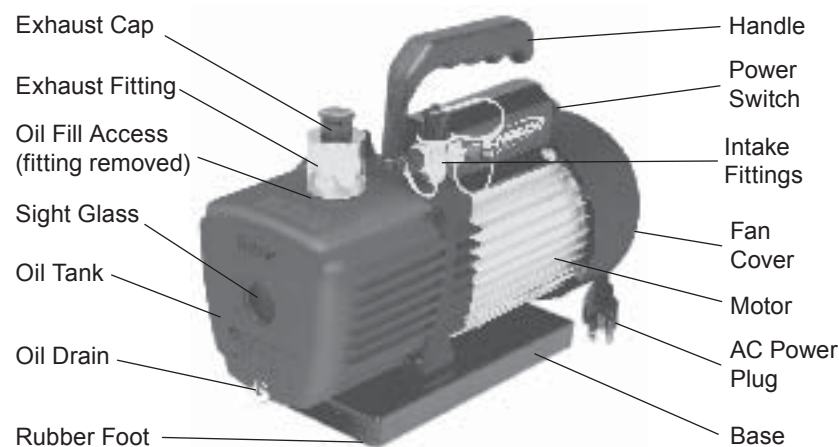

Operation

Check the pump-oil level as viewed through the sight glass before each use. Add oil as necessary through the oil fill access. Use only high grade vacuum pump oil with the following specifications:

Kinematic viscosity 104° F	46
Viscosity index	100.0
Flash point	437

Remove intake fitting cap and connect pump to the system being evacuated using a hose with appropriate fittings. Keep the connection as short as possible, and ensure that all connections are sealed and not leaking. If desired, use a vacuum gauge manifold set to monitor the vacuum level.

Remove exhaust fitting cap; plug pump into an appropriate AC outlet; and then turn ON pump to begin the evacuation process.

After pumping is complete: turn OFF pump; disconnect power plug; remove connecting hose; and reinstall intake and exhaust caps.

Warnings & Cautions

Warnings:

- Do not evacuate combustible, explosive, or poisonous gases.
- Do not operate the vacuum pump in the rain.
- Do not pull out or insert power plug, or turn ON the pump in an explosive atmosphere.
- If using the pump in a confined area, connect a hose to the pump's exhaust fitting and route the hose to the outside.

- Power the pump from a grounded AC outlet. Consult a professional electrician to ensure proper grounding.
- Do not use a defective AC power plug or outlet.

Cautions:

- Do not evacuate gases that corrode metal or react chemically with the pump-oil.
- If the air being evacuated contains dust or is above 175 °F (80 °C), then a filter or cooling device should be installed at the pump's intake.
- Do not operate the pump for more than 3 minutes with the intake open to the atmosphere.
- For proper cooling and air ventilation, keep the sides of the pump at least 1" (2 cm) away from walls, and allow 2" (5 cm) for the front and rear of the pump.
- Do not lay heavy objects on the power cord, or allow the power cord to become pinched.
- Operate the vacuum pump in a dry, well ventilated area.
- Do not operate the pump below an ambient temperature of 40 °F (5 °C).
- Do not use as a compression pump or transfer pump.
- Do not operate without clean vacuum pump oil.
- Do not block the exhaust fitting when the pump is operating.
- When pulling out the power plug, grip the plug rather than the cord.

Troubleshooting

Problem	Probable Cause	Remedy
Pump does not produce desired vacuum	Oil level low	Add oil until level is correct as viewed through sight glass
	Oil emulsified or dirty	Replace with fresh high grade vacuum pump oil
	Oil inlet or oil flow is blocked	Clean oil inlet and filtering screen
	System leak	Check system being evacuated for leakage and repair
	Pump too small	Check the size of system being evacuated and choose proper pump
	Pump worn	Rebuild or replace pump
Oil leakage	Oil seal damaged	Install new oil seal
	Oil tank connection loose or damaged	Tighten oil tank screws, or replace gasket
Oil injection	Too much oil in tank	Drain oil until level is correct as viewed through sight glass
	Pump too small	Check the size of system being evacuated and choose proper pump
Difficult starting	Oil temperature too low	Open intake to atmosphere and intermittently start motor to heat pump oil
	Foreign matter in pump	Clean pump by replacing pump-oil
	Motor defective	Replace motor

Maintenance and Service

If the vacuum pump motor stops because of an overload condition, first turn OFF the pump and open its intake to the atmosphere. Wait 5 minutes (press the RESET button if present) and try restarting the pump. If the overload condition persists, refer to *Troubleshooting – Difficult starting* on Page 6.

Keep pump clean and avoid foreign matter from entering the pump.

Keep the vacuum pump oil at the correct level during normal operation as viewed through the sight glass — **do not run pump without oil.**

Using clean, fresh vacuum pump oil is a critical part of achieving the desired vacuum. Replace the pump-oil if the oil becomes dirty and looks turbid, or contains water or other volatile matter. When replacing the oil, first thin down the oil by running the pump for 30 minutes with the intake closed. Stop the pump, remove the exhaust fitting and remove the oil drain plug, allowing the oil to drain. Run pump for 1–2 minutes with intake open while adding a small amount of clean pump-oil through the intake to flush out any residual oil in the pumping chamber. Repeat this process several times until the pump is clean. Replace the oil drain plug, and then fill the oil tank through the oil fill access with fresh vacuum pump oil to the desired level as viewed through the sight glass.

When storing the pump, install the intake and exhaust caps and place the pump in dry location.

Only qualified technicians should attempt to disassemble and repair the vacuum pump. Service performed by unauthorized personnel during the warranty period will void the pump's warranty. For warranty repair and replacement parts, please call Bacharach Service at 724-334-5000.

Exploded Drawing

Notes:

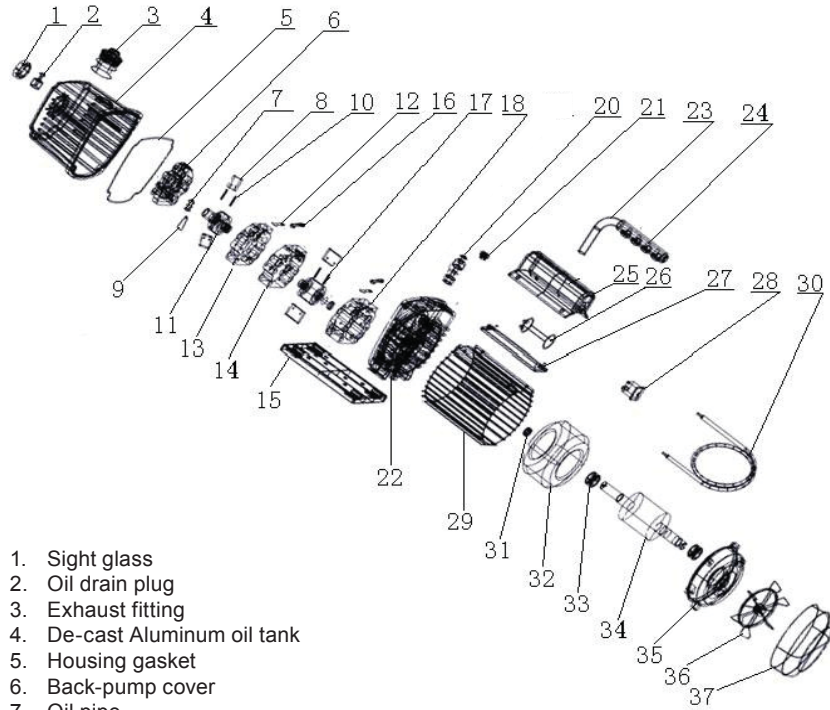

- | | | |
|------------------------------|--------------------|------------------|
| 1. Sight glass | 20. Inter port | 31. Shaft seat |
| 2. Oil drain plug | 21. Cap-like cover | 32. Motor Stator |
| 3. Exhaust fitting | 22. Trestle | 33. Bearing |
| 4. De-cast Aluminum oil tank | 23. Handle | 34. Motor rotor |
| 5. Housing gasket | 24. Sleeve | 35. Motor cover |
| 6. Back-pump cover | 25. Cover | 36. Fan |
| 7. Oil pipe | 26. Capacitor | 37. Fan cover |
| 8. Rotary-vane | 27. Board | |
| 9. Spiral piece | 28. Switch | |
| 10. Rotary-vane spring | 29. Motor hull | |
| 11. Back-pump rotor | 30. Outlet | |
| 12. Valve piece | | |
| 13. Back-pump stator | | |
| 14. Middle fence | | |
| 15. Molded base | | |
| 16. Restricting piece | | |
| 17. Front pump rotor | | |
| 18. Front pump stator | | |



Headquarters:

621 Hunt Valley Circle, New Kensington, PA 15068

Ph: 724-334-5000 • Fax: 724-334-5001 • Toll Free: 800-736-4666

Website: www.bacharach-inc.com • E-mail: help@bacharach-inc.com

Printed in U.S.A.

